

Twist & Dry®

Twist & Dry® Component System

The Twist & Dry component system was developed for the spray dryer industry. The TD-K was next developed as an innovative solution to expand spray dryer capacity up to 689 bar. The patented locking system locks components into place prior to installation. There are many interchangeable swirls and orifice disks available for varying the flow rates of the nozzles. Many materials are also available to allow for high temperature usage without leakage.

SPRAY SET-UPS

Twist & Dry nozzles have almost 1,000 different combinations of swirl and orifice discs to provide exactly the right flow rate and angle for your needs. The spray angle and flow rate are determined by the "swirl/orifice set-up" – a specific combination of one swirl disc and one orifice. To locate the right swirl and orifice combination refer to the following TD-K, Twist & Dry, and TDL pages.

Spray angle is determined by the orifice geometry. Carriers and bodies differ in both material and design to accommodate both high temperature and pressure. The robust design allows for many material choices and combinations.



TDL Low Flow Twist & Dry® Assembly

TD-K High Pressure Series

The TD-K is a high pressure nozzle in the Twist & Dry series. The series includes models TD-7K rated up to 483 bar and the TD-10K rated up to 689 bar.

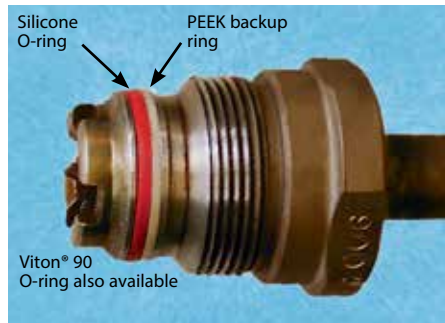

Side View: TD-K body with PEEK backup ring

Often higher pressures can increase yield and save money. **Please visit www.bete.com/td-k.html.**

Twist & Dry Series

The Twist & Dry is a BETE original design that answers the needs of the spray drying industry. The BETE design offers superior performance as well as an innovative patented locking mechanism. Replace the wear parts of your spray dry nozzles without turning the lances upside down.

The BETE Twist & Dry is designed with the operator in mind. If you operate and maintain a spray dryer, you know just how difficult it can be to replace the nozzle wear parts.

These unique features of the Twist & Dry design makes this chore much easier: fewer parts; rugged design – one piece swirl unit \ greatly reduces breakage of tungsten carbide pieces; easy assembly – the BETE Twist & Dry locking system keeps the swirl chamber and orifice "locked" into position during assembly; Materials – corrosion-resistant 303 Stainless Steel carrier, Tungsten Carbide swirl unit and orifice disk, Viton® O-rings, other materials are available. BETE provides software support, also: users of the Twist & Dry receive free-of-charge computer software that greatly simplifies selecting the correct swirl unit and orifice disk.

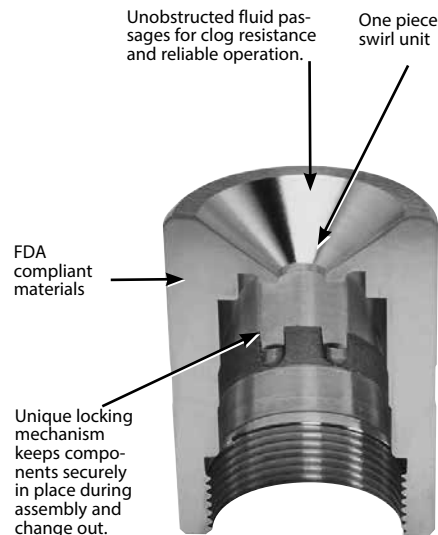

Cutaway view of the Twist & Dry carrier



TD swirl disc



TD orifice disc



BETE Twister tool is specially designed for the Twist & Dry nozzle series.

SPECIAL PURPOSE

TO ORDER: specify pipe size, connection type, nozzle number, and material.

Twist & Dry® Components & Options

Twist & Dry Material Selection Guide					
Pressure		Temperature			
bar	psi	up to 250°F (121°C)		up to 400°F (204°C)	up to 450°F (232°C)
689	10,000	TD 10K Viton 90 O-ring w/PEEK Backup Ring Carrier in Duplex 2205 TD 10K only available in Carriers 5 and 11		TD 10K Viton 90 O-ring w/PEEK Backup Ring Carrier in Duplex 2205 TD 10K only available in Carriers 5 and 11	TD 10K Silicone O-ring w/PEEK Backup Ring Carrier in Duplex 2205 TD 10K only available in Carriers 5 and 11
483	7,000	TD 7K Viton 90 O-ring w/PEEK Backup Ring		TD 7K Viton 90 O-ring w/PEEK Backup Ring	TD 7K Silicone O-ring w/PEEK Backup Ring
345	5,000	TD Viton 90 O-ring			
241	3,500			TD Viton 90 O-ring	
55	800				TD Silicone O-ring

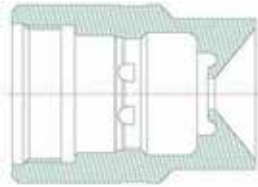

Carrier C14 (shown)
Carrier 1C11 - without lug

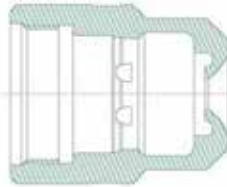

Standard TD Carrier
Carrier 2C12 (shown)
Carrier 5C15 - without lug

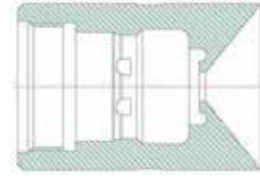

Carrier 01C110 (shown)
Carrier 21C112 - without lug

To Order: Spray Set-up Number

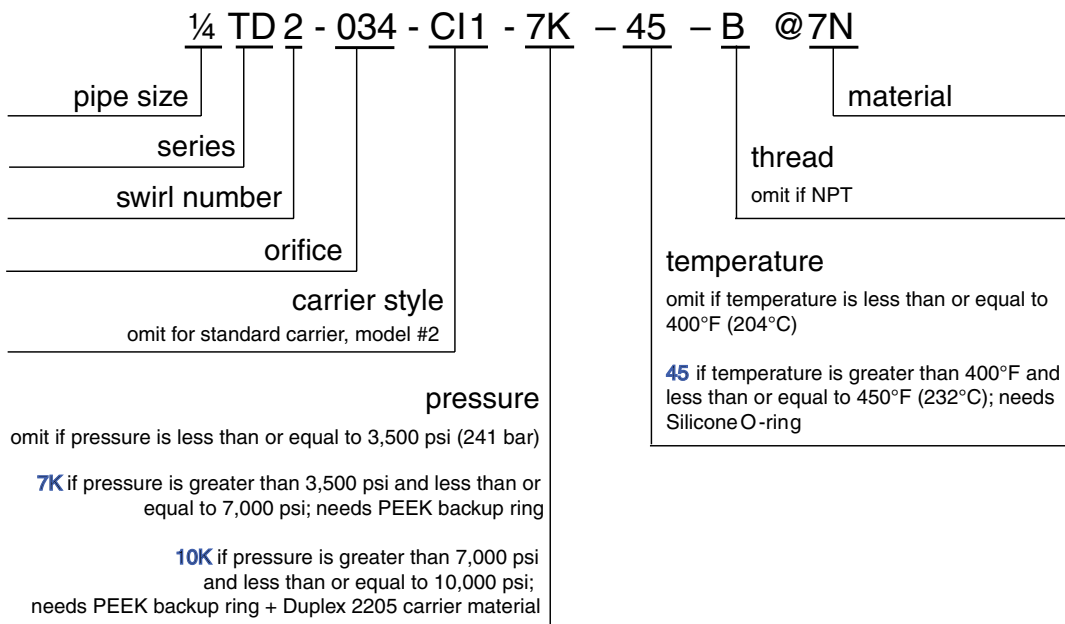

PEEK™ is a registered trademark of Victrex.

SPECIAL PURPOSE

CALL 01273 400092
Call for expert advice on all special purpose nozzles

TD/TD-K

Twist & Dry® Hollow Cone

DESIGN FEATURES

- Patented locking mechanism for quick and easy change-out and maintenance
- Choose TD-K to operate at high pressures for greater yield capacity
- PEEK backup ring with Viton® 90 O-rings or Silicone (for higher temperatures)
- Female-threaded or butt weld pipe connections
- Easy assembly, no special tools required
- Orifice size: 0.864mm through 3.99mm

- Interchangeable swirl and orifice discs for variable patterns and flow rates
- Please visit www.bete.com/td-k.html for more information on the TD-K nozzle

SPRAY CHARACTERISTICS

- Hollow Cone
- Flow rates: 35.3 to 5,970 l/hr
- Spray angle: 50°, 55°, 60°, 65°, 70°, 75°, 80°

Check valve available upon request



Female



70° Hollow Cone



Cutaway view of carrier showing lugs and BETE's unique locking design

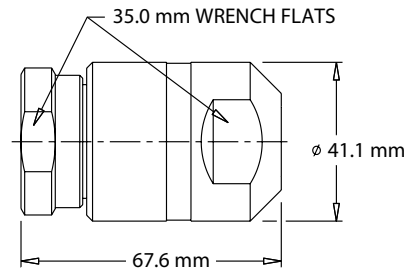

Pipe Size	Weight (g)
1/4"	539
3/8"	524
1/2"	510
3/4"	482

Dimensions are approximate. Check with BETE for critical dimension applications.

Twist & Dry/TD-K Flow Rates and Dimensions Hollow Cone, 50° to 80° Spray Angles, 1/4", 3/8", 1/2" and 3/4" Pipe Size NPT, BSP or Welded

Female Pipe Size	Nozzle Number	Spray Angle	Swirl	Orifice (mm)	K Factor	LITERS PER HOUR @ BAR											
						15 bar	35 bar	50 bar	70 bar	90 bar	100 bar	120 bar	150 bar	175 bar	200 bar	275 bar	350 bar
1/4"	TD2-34	70°	SW2	0.864	9.12	35.3	53.9	64.5	76.3	86.5	91.2	99.9	112	121	129	151	171
	TD1-37	80°	SW1	0.940		35.3	53.9	64.5	76.3	86.5	91.2	99.9	112	121	129	151	171
3/8"	TD2-40	75°	SW2	1.02	11.4	44.1	67.4	80.6	95.3	108	114	125	140	151	161	189	213
	TD1-49	85°	SW1	1.24		44.1	67.4	80.6	95.3	108	114	125	140	151	161	189	213
1/2"	TD4-34	60°	SW4	0.864	13.7	53.0	80.9	96.7	114	130	137	150	167	181	193	227	256
	TD3-40	70°	SW3	1.02		53.0	80.9	96.7	114	130	137	150	167	181	193	227	256
3/4"	TD5-34	50°	SW5	0.864	16.0	61.8	94.4	113	133	151	160	175	195	211	226	265	298
	TD4-40	65°	SW4	1.02		61.8	94.4	113	133	151	160	175	195	211	226	265	298
1/2"	TD4-43	65°	SW4	1.09	18.2	70.6	108	129	153	173	182	200	223	241	258	302	341
	TD3-49	75°	SW3	1.24		70.6	108	129	153	173	182	200	223	241	258	302	341
3/4"	TD6-37	50°	SW6	0.940	20.5	79.4	121	145	172	195	205	225	251	271	290	340	384
	TD5-40	60°	SW5	1.02		79.4	121	145	172	195	205	225	251	271	290	340	384
	TD4-46	70°	SW4	1.17		79.4	121	145	172	195	205	225	251	271	290	340	384
	TD3-55	75°	SW3	1.40		79.4	121	145	172	195	205	225	251	271	290	340	384
3/4"	TD6-40	50°	SW6	1.02	22.8	88.3	135	161	191	216	228	250	279	301	322	378	426
	TD5-43	60°	SW5	1.09		88.3	135	161	191	216	228	250	279	301	322	378	426
	TD4-52	70°	SW4	1.32		88.3	135	161	191	216	228	250	279	301	322	378	426
3/4"	TD5-49	60°	SW5	1.24	25.1	97.1	148	177	210	238	251	275	307	332	355	416	469
	TD4-58	70°	SW4	1.47		97.1	148	177	210	238	251	275	307	332	355	416	469
	TD3-67	80°	SW3	1.70		97.1	148	177	210	238	251	275	307	332	355	416	469

$$\text{Flow Rate (l/hr)} = K\sqrt{\text{bar}}$$

Standard Materials: 316 Stainless Steel, Tungsten Carbide. Other materials available.

Spray angle performance varies with pressure. Contact BETE for specific data on critical applications.

Twist & Dry Flow Rates and Dimensions
Hollow Cone, 50° to 80° Spray Angles, 1/4", 3/8", 1/2" and 3/4" Pipe Size NPT, BSP or Welded

Female Pipe Size	Nozzle Number	Spray Angle	Dia Swirl (mm)	K Factor	LITERS PER HOUR @ BAR											
					15 bar	35 bar	50 bar	70 bar	90 bar	100 bar	120 bar	150 bar	175 bar	200 bar	275 bar	350 bar
	TD6-46	55°	SW6 1.17	27.4	106	162	193	229	259	273	300	335	362	387	453	512
	TD5-52	65°	SW5 1.32													
	TD4-61	75°	SW4 1.55													
	TD3-70	80°	SW3 1.78													
	TD6-52	55°	SW6 1.32	31.9	124	189	226	267	303	319	349	391	422	451	529	597
	TD5-58	65°	SW5 1.47													
	TD4-70	75°	SW4 1.78													
	TD7-49	50°	SW7 1.24	36.5	141	216	258	305	346	365	399	447	482	516	605	682
	TD6-55	60°	SW6 1.40													
	TD5-64	70°	SW5 1.63													
	TD4-76	80°	SW4 1.93													
	TD7-52	50°	SW7 1.32	41.0	159	243	290	343	389	410	449	502	543	580	680	767
	TD6-61	60°	SW6 1.55													
	TD5-70	70°	SW5 1.78													
	TD7-58	55°	SW7 1.47	45.6	177	270	322	381	432	456	499	558	603	645	756	853
	TD6-64	65°	SW6 1.63													
	TD5-76	75°	SW5 1.93													
	TD4-91	80°	SW4 2.31													
	TD7-61	55°	SW7 1.55	50.1	194	297	355	419	476	501	549	614	663	709	831	938
	TD6-70	65°	SW6 1.78													
	TD5-82	75°	SW5 2.08													
	TD7-64	55°	SW7 1.63	54.7	212	324	387	458	519	547	599	670	724	773	907	1020
	TD6-76	65°	SW6 1.93													
	TD5-88	75°	SW5 2.24													
	TD8-67	50°	SW8 1.70	68.4	265	404	483	572	649	684	749	837	904	967	1130	1280
	TD7-76	60°	SW7 1.93													
	TD6-88	70°	SW6 2.24													
	TD5-109	80°	SW5 2.77													
	TD8-76	50°	SW8 1.93	82.0	318	485	580	686	778	820	899	1010	1090	1160	1360	1540
	TD7-85	65°	SW7 2.16													
	TD6-103	75°	SW6 2.62													
	TD8-82	55°	SW8 2.08	95.7	371	566	677	801	908	957	1050	1170	1270	1350	1590	1790
	TD7-97	65°	SW7 2.46													
	TD6-115	75°	SW6 2.92													
	TD9-82	50°	SW9 2.08	109	424	647	773	915	1040	1090	1200	1340	1450	1550	1810	2050
	TD8-91	60°	SW8 2.31													
	TD7-106	70°	SW7 2.69													
	TD6-127	80°	SW6 3.23													
	TD9-88	50°	SW9 2.24	123	477	728	870	1030	1170	1230	1350	1510	1630	1740	2040	2300
	TD8-100	60°	SW8 2.54													
	TD7-118	70°	SW7 3.00													
	TD6-142	80°	SW6 3.61													
	TD9-94	55°	SW9 2.39	137	530	809	967	1140	1300	1370	1500	1680	1810	1930	2270	2560
	TD8-106	65°	SW8 2.69													
	TD7-127	75°	SW7 3.23													
	TD9-106	55°	SW9 2.69	160	618	944	1130	1340	1510	1600	1750	1950	2110	2260	2650	2980
	TD8-121	65°	SW8 3.07													
	TD7-145	75°	SW7 3.68													
	TD10-103	50°	SW10 2.62	182	706	1080	1290	1530	1730	1820	2000	2230	2410	2580	3020	3410
	TD9-115	60°	SW9 2.92													
	TD8-133	70°	SW8 3.38													
	TD10-118	55°	SW10 3.00	205	794	1210	1450	1720	1950	2050	2250	2510	2710	2900	3400	3840
	TD9-127	60°	SW9 3.23													
	TD8-145	70°	SW8 3.68													
	TD9-136	65°	SW9 3.45	228	883	1350	1610	1910	2160	2280	2500	2790	3020	3220	3780	4260
	TD8-157	75°	SW8 3.99													
	TD9-148	65°	SW9 3.76	251	971	1480	1770	2100	2380	2510	2750	3070	3320	3550	4160	4690
	TD10-136	60°	SW10 3.45	274	1060	1620	1930	2290	2590	2740	3000	3350	3620	3870	4540	5120
	TD9-154	70°	SW9 3.91													
	TD10-151	60°	SW10 3.84	296	1150	1750	2100	2480	2810	2960	3250	3630	3920	4190	4910	5540
	TD10-157	65°	SW10 3.99	319	1240	1890	2260	2670	3030	3190	3500	3910	4220	4510	5290	5970

Flow Rate (l/hr) = $K\sqrt{\text{bar}}$

Standard Materials: 316 Stainless Steel, Tungsten Carbide. Other materials available.

Spray angle performance varies with pressure. Contact BETE for specific data on critical applications.

TDL

Twist & Dry® Low Flow Hollow Cone

DESIGN FEATURES

- Patented locking mechanism for quick and easy change-out and maintenance
- 2-piece body for easy maintenance
- Lower flow rates than the Twist & Dry series
- Female-threaded or butt weld pipe connections
- Orifice size: 0.457mm through 1.47mm
- Interchangeable swirl and orifice discs for variable patterns and flow rates

SPRAY CHARACTERISTICS

- Hollow Cone
- Flow rates: 11.3 to 469 l/hr
- Spray angle: 70° - 75°



Female



70° Hollow Cone

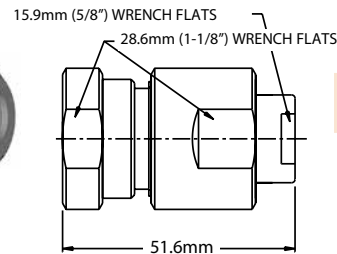

Pipe Size	Weight (g)
1/4"	119
3/8"	107

Dimensions are approximate. Check with BETE for critical dimension applications.

TDL Flow Rates and Dimensions

Hollow Cone, 70° to 75° Spray Angles, 1/4" and 3/8" Pipe Size NPT, BSP or Welded

Female Pipe Size	Nozzle Number	Dia. Swirl [mm]	K	LITERS PER HOUR @ BAR												
				15 bar	35 bar	50 bar	70 bar	90 bar	100 bar	120 bar	150 bar	175 bar	200 bar	275 bar	350 bar	
1/4"	TDL4-18	\$WL4	0.457	2.92	11.3	17.3	20.6	24.4	27.7	29.2	32.0	35.7	36.6	41.3	48.4	54.6
	TDL4-20	\$WL4	0.508	3.10	12.0	18.3	21.9	25.9	29.4	31.0	34.0	38.0	41.0	43.8	51.4	58.0
	TDL4-22	\$WL4	0.559	3.42	13.2	20.2	24.2	28.6	32.4	34.2	37.4	41.9	45.2	48.3	56.7	64.0
	TDL4-24	\$WL4	0.610	3.92	15.2	23.2	27.7	32.8	37.2	39.2	42.9	48.0	51.9	55.4	65.0	73.3
	TDL4-27	\$WL4	0.686	4.56	17.7	27.0	32.2	38.1	43.2	45.6	49.9	55.8	60.3	64.5	75.6	85.3
OR	TDL1-22	\$WL1	0.559	5.01	19.4	29.7	35.5	41.9	47.6	50.1	54.9	61.4	66.3	70.9	83.1	93.8
	TDL1-24	\$WL1	0.610	5.70	22.1	33.7	40.3	47.7	54.0	57.0	62.4	69.8	75.4	80.6	94.5	107
	TDL1-27	\$WL1	0.686	6.61	25.6	39.1	46.7	55.3	62.7	66.1	72.4	80.9	87.4	93.5	110	124
	TDL1-30	\$WL1	0.762	7.52	29.1	44.5	53.2	62.9	71.3	75.2	82.4	92.1	99.5	106	125	141
	TDL2-30	\$WL2	0.762	9.12	35.3	53.9	64.5	76.3	86.5	91.2	100	112	121	129	151	171
	TDL2-33	\$WL2	0.838	10.3	39.7	60.7	72.5	85.5	97.3	103	112	126	136	145	170	192
	TDL2-36	\$WL2	0.914	11.4	44.1	67.4	80.6	95.3	108	114	125	140	151	161	189	213
3/8"	TDL2-38	\$WL2	0.965	12.1	46.8	71.5	85.4	101	115	121	132	148	160	171	200	226
	TDL2-40	\$WL2	1.02	13.2	51.2	78.2	93.5	111	125	132	145	162	175	187	219	247
	TDL2-42	\$WL2	1.07	13.7	53.0	80.9	96.7	114	130	137	150	167	181	193	227	256
	TDL2-44	\$WL2	1.12	14.1	54.7	83.6	100	118	134	141	155	173	187	200	234	264
	TDL2-46	\$WL2	1.17	14.8	57.4	87.6	105	124	141	148	162	181	196	209	246	277
	TDL2-48	\$WL2	1.22	16.0	61.8	94.4	113	133	151	160	175	195	211	226	265	298
	TDL2-50	\$WL2	1.27	16.6	64.4	98.4	118	139	158	166	182	204	220	235	276	311
	TDL2-52	\$WL2	1.32	18.0	69.7	107	127	151	171	180	197	220	238	255	298	337
	TDL2-54	\$WL2	1.37	18.7	72.4	111	132	156	177	187	205	229	247	264	310	350
	TDL2-56	\$WL2	1.42	19.1	74.1	113	135	160	182	191	210	234	253	271	317	358
TDL3-54	TDL3-50	\$WL3	1.27	20.4	79.1	121	144	171	194	204	224	250	270	289	339	382
	TDL3-52	\$WL3	1.32	21.8	84.4	129	154	182	207	218	239	267	288	308	361	408
	TDL3-54	\$WL3	1.37	23.0	89.1	136	163	193	218	230	252	282	304	326	382	431
	TDL3-56	\$WL3	1.42	24.4	94.4	144	172	204	231	244	267	299	323	345	404	456
	TDL3-58	\$WL3	1.47	25.1	97.1	148	177	210	238	251	275	307	332	355	416	469

Flow Rate (l/hr) = $K \sqrt{\text{bar}}$

Standard Materials: Stainless Steel, Tungsten Carbide. Other materials available.

Spray angle performance varies with pressure. Contact BETE for specific data on critical applications.

SPECIAL PURPOSE

TO ORDER: specify pipe size, connection type, nozzle number, and material.